

# Bird-Shock® Flex-Track™

Bird Barrier America, Inc.  
 20925 Chico Street  
 Carson, CA 90278  
 Phone (310) 527-8005, (800) 503-5444  
 Fax (310) 527-8005  
 E-mail: [bbasales@birdbarrier.com](mailto:bbasales@birdbarrier.com)  
 Web: [www.birdbarrier.com](http://www.birdbarrier.com)

CSI Division: 10296  
 Bird Barrier Bird-Shock Flex-Track System

## MR-MANUFACTURER

Bird Barrier America, Inc. manufactures Bird-Shock Flex-Track. It features high-grade stainless steel flat braid-strips which are sewn onto a flexible, ultra-violet stabilized PVC plastic. The tracks are offered in fifty-foot lengths, and four colors: 1. Black, 2. Beige, 3. Gray and 4. Brick Red. The stainless steel braid is sewn to the PVC using "Tenara", a lifetime-warranted expanded polytetrafluorocethylene (PTFE) thread. A solar or 110volt charge unit supplies the track with an intermittent pulse of high voltage, low amperage electricity. The pulse of electricity does not harm the bird; it simply conditions them not to return to that area. Heavily insulated, copper lead-out wire delivers the intermittent charge from the charge unit to the tracks.

## One-Sided Ledge (Against Wall)

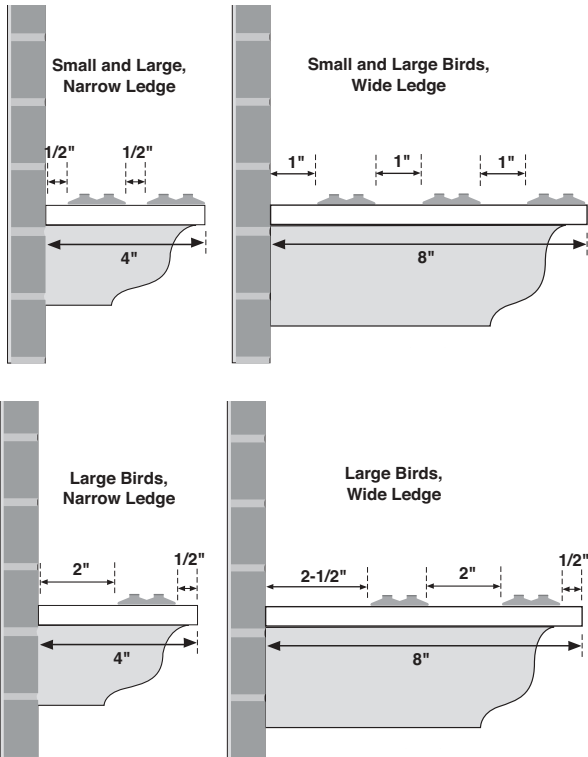

**Flex-Track Installation Schematic**

## Two-Sided Ledge

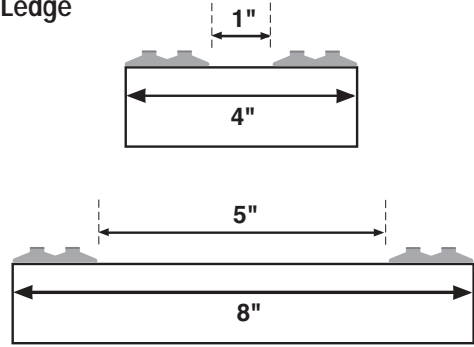

## Signs and Letters

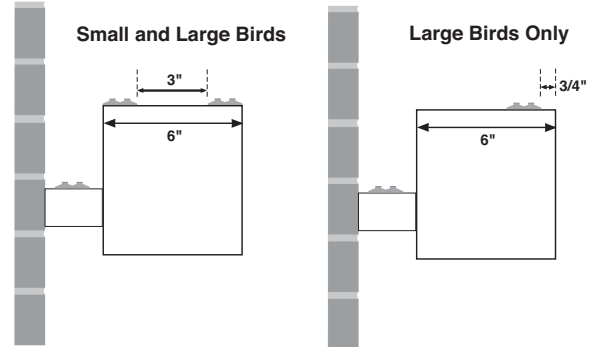

## PR-PRODUCT PRESENTATION

Bird-Shock Flex-Track electrified bird deterrent system is effective against all species of birds to deter them from loafing, roosting and nesting on ledges at all pressure levels. Bird-Shock Flex-Track is recommended for high pressure situations (where birds are roosting or nesting generally).

The track is glued to the surface and is connected together using crimp-connectors. Tracks are installed on the leading edges of a ledge, or appropriately where determined necessary by the installer; based on bird species and bird pressure.

The solar charge unit needs to face due South, so that it receives at least two hours of direct sun light a day. The 110 volt charger needs to be out of the weather, an electrician maybe needed to install a junction box for this purpose.

Workers and unsuspecting persons should be made aware that there is an electrified bird deterrent system in place so they are not caught off guard and terrified by touching the track system. Warning notices are printed directly on the track.

## Track

Material: Ultra-violet stabilized flexible PVC, Stainless Steel Braid Strips and Tenara thread.

Width: 1.5" (3.7cm)

Height: 1/4" (.6cm)

Length: 50 feet (15.24m)  
Mounting: Glue

#### Charge units

Solar  
Material: Durable thermo Plastic  
Width: 5 3/4" (14.6cm)  
Height: 9 1/8" (23.2cm)  
Depth: 4 3/8" (11.1cm)  
Mounting: Screw in place

#### **UA-USES, APPLICATIONS**

Bird-Shock Flex-Track can be used to deter all types of birds from loafing, roosting and nesting on high pressure exposed ledges. The intermittent bursts of electric protects the ledge and conditions birds not to land in that area, causing the birds to take their business elsewhere. Bird-Shock Flex-Track can be used in combination to cover any width ledge, and up to 6 inches can be left unprotected between rows of track. The Bird-Shock Flex-Track system is not recommended to be installed in areas where children or unsuspecting workers can come into contact with the system. The Bird-Shock Flex-Track system is easy to install, all you need is a little electric knowledge. The track can not be identified from the ground when installed on a parapet wall.

#### **AI-ASSEMBLY, INSTALLATION**

Finding a suitable location for the charge unit is required before installing the track system. Whenever possible, position the charger unit as near the starting point of the track as possible. Solar chargers must face due south to capture as much sunlight as possible while the 110 volt chargers should be installed out of the weather with no over-head obstructions or inside a closed area. After the tracks are installed, lead-out wire is connected from the charger to the track, which carries the bursts of electric from the charge unit to the track.

Bird-Shock Flex-Track is installed to a ledge or wall with glue. Bird Barrier Bond (cure time 2-4 hours) will fasten the tracks to any clean, dry, stable surface. The 50' tracks are connected together by male/female connectors.

Special instructions, that describe corners and other complex situations, are supplied with the product.

#### **MF-MATERIALS, FINISHES**

Bird-Shock Flex-Track track is made of ultra-violet stabilized PVC with two stainless steel braid-strips that are sewn together. The lead-out wire is custom made and is the only lead-out wire that should be used for a Bird-Shock

Flex-Track installation due to the extra thick insulation. Charge units are made of durable plastic.

#### **TS-TECHNICAL SUPPORT**

Bird Barrier's knowledgeable field representatives are available to assist in any aspect of evaluation, product recommendation and even local certified installation. Call 800-503-5444, or fax drawings and other pertinent information to 310-527-8005. Free literature, job evaluation worksheets and installation information is available.

#### **SPECIFICATION GUIDELINES**

##### **General**

##### 1.1 Description

1.1.1 Install Bird-Shock Flex-Track on exposed ledges where birds land, loaf, roost or nest, to prevent damage from droppings.

##### 1.2 Quality Assurance

1.2.1 Obtain technical literature from manufacturer or distributor, telephone consultation and plan/photograph evaluation.

1.2.2 Utilize certified installation companies in your area who are fully skilled with Bird Barrier products, and carry the proper insurance coverage.

1.2.3 Utilize labor recommended by Bird Barrier for especially challenging applications.

##### 1.3 Submittals

1.3.1 Submit manufacturer's samples, catalog cuts, shop sketches and other descriptive material.

##### 1.4 Product Handling

1.4.1 Protect Bird-Shock Flex-Track from damage before, during and after installation.

1.4.2 If damage occurs to Bird-Shock Flex-Track, make all replacements immediately.

##### **Products**

##### 2.1 Acceptable Manufacturer

2.1.1 Bird Barrier America, Inc., 20925 Chico Street, Carson, CA 90746. Phone 800-503-5444, Fax 310-527-8005

##### 2.2 Model Designation

2.2.1 Solar charge unit

2.2.2 110Volt charge unit

2.2.3 Ultra-violet flexible PVC Track

2.2.4 Lead-out wire

2.2.5 Connector devices

2.2.6 Special tools

## Material

### *Solar Charge Unit*

Range: 500 feet

Input Voltage: 4V, .02amp, .08W

Output Voltage: 7.5KV (+or-) 2KV, 3amp (+or-)1 amp.

### *110 Volt Charge Unit*

UL Approved

Intermittent DC output

Range: 500 feet

Input Voltage: 110-120 VAC, 60 Hz,.035amp, 10W

Output Voltage: 800V (+or-) 100 V, 10mA (+or-) 2mA

Intermittent AC output

### *Track*

Material: Ultra-violet stabilized PVC, stainless steel braid-strips

Width: 1.5" (3.7cm)

Height: 1/4" (.6cm)

Length: 50 feet (15.24m)

Mounting: Glue

### *Lead-out Wire*

Material: Heavy insulated 14 double gauge copper (+) wire,

Width: 5/8" (1.6cm)

Height: 3/8" (.6cm)

Mounting Clip: Plastic wire loops

Length: 50 feet (15.24m)

## 2.3 Mounting Systems

2.3.1 Concrete, Steel and Stone: Bird Barrier Bond.

## 3.3 Installation

3.3.1 Install the Bird-Shock Flex-Track System as recommended in the installation instructions, which are supplied by the manufacturer. The track shall be installed next to the leading edge of the ledge, if the ledge is wider than 8' with a back wall, another track should be installed at the rear of the ledge.

3.3.2 Bird-Shock Flex-Track track must cover the outer perimeter of ledges. The Bird-Shock Flex-Track shall extend to each corner. The Bird-Shock Flex-Track is an anti-landing device, not a barrier. It is acceptable to leave up to 6 inch's of clearance between Bird-Shock Flex-Track tracks or three inch's between the Bird-Shock Flex-Track track and the back wall of the ledge.

3.3.3 Bird Barrier Bird-Shock Flex-Track shall be installed straight, or shall follow the contours of the architecture perfectly. Installation of the tracks unevenly to the ledge will result in an unattractive and possible an ineffective installation. Refer to Bird Barrier Bird-Shock Flex-Track installation literature for details.

## 3.4 Inspection

3.4.1 Visually inspect the Bird-Shock Flex-Track for loose connections, debris or other problems related to poor installation or surface preparation.

3.4.2 Repair as necessary immediately.

## **OM-OPERATION, MAINTENANCE**

If the Bird-Shock Flex-Track is installed per our specifications, the product should be virtually maintenance free. Occasionally, leaves may fall on the track or birds might drop debris on the track in an attempt to build a nest, a monthly service contract is recommended to remove any debris and check connection of system to prevent system from becoming inoperable.

## Execution

### 3.1 Examination

3.1.1 Examine installation area. Notify architect of detrimental work conditions.

3.1.2 Do not proceed until conditions are corrected.

### 3.2 Surface Preparation

3.2.1 Ledges and mounting surfaces shall be cleaned with a combination of Bird Barrier's cleaning products, Dissolve-It, or Absorb-It when applicable. Surfaces should then be clean, dry and free of peeling paint, rust, bird droppings or other debris. Bird droppings must be removed in a safe manner; large quantities should be removed and disposed of by reputable waste removal companies.

3.2.2 Remove or repair articles that may damage the Bird-Shock Flex-Track system after installation, such as tree limbs, brush, and loose parts of the building.



### One-Sided Ledge (up to a wall)

For smaller birds multiple rows should be placed closer together; but for larger birds, more spacing is acceptable. These diagrams indicate the most extreme application for heavy pressure settings. If the pressure is lighter, you may be able to apply fewer rows, but you should always apply the row closest to the outer edge.

Large Birds: Crows, Grackles, Gulls, Pigeons  
Small Birds: Sparrows, Starlings, Swallows

### Top View

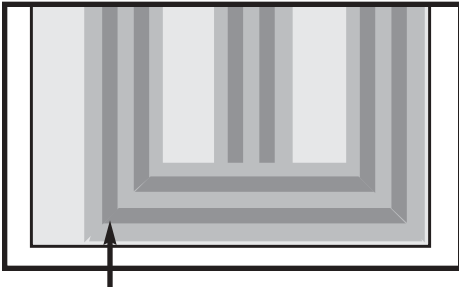

Run track along end of ledge as well

### Two-Sided Ledge

One row down each edge will give the results needed. Only in extreme circumstances would a third row down the center of a ledge be necessary.

### Top View

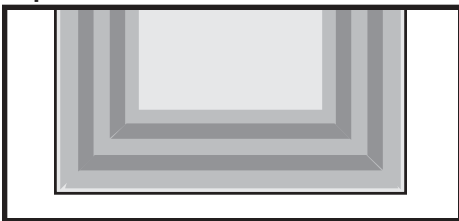

### Signs and Letters

For larger birds one row on the outer edge is generally sufficient (except under very heavy pressure), but for small birds, the multiple rows are a must. On even wider signs, a third row may be necessary.

### Top View

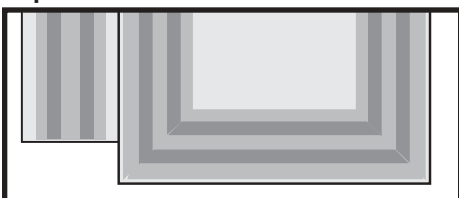

### Dissected View

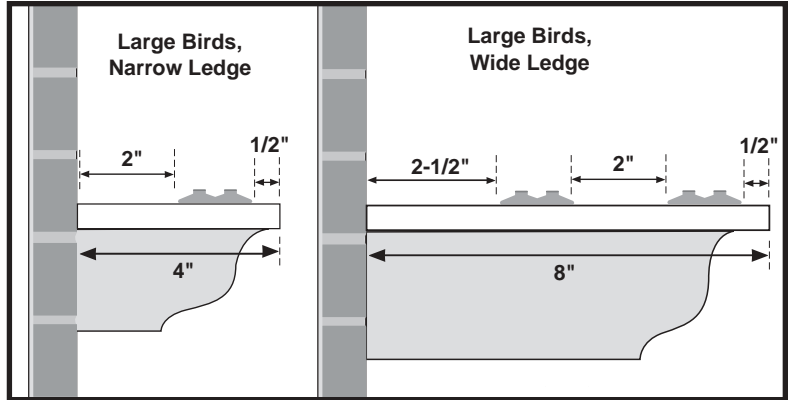

### Dissected View

